

# MH Mechanical-Manual Lift (Trapezoidal Screw, Manual)

## Trapezoidal Screw / Manual

**S**mooth manual operation when loaded by using trapezoidal screw.

**MAJOR FEATURES OF THE MH SERIES**

- Smooth operation with loads while lowering and raising
- No-hydraulic drift
- Strong structure by using trapezoidal screw.



MH-300-5050

During Lowering



MH-100-2020W

During Lowering



\* Wrench included with all MH Lift Tables.

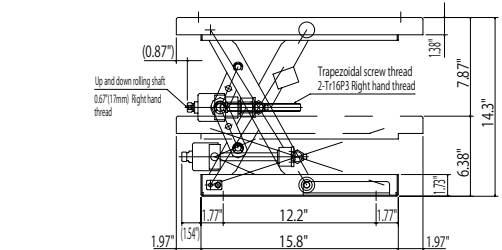
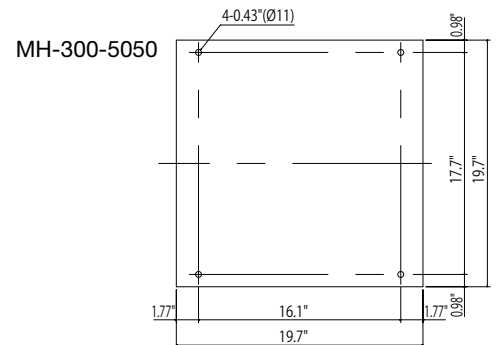

MH-100-2020W

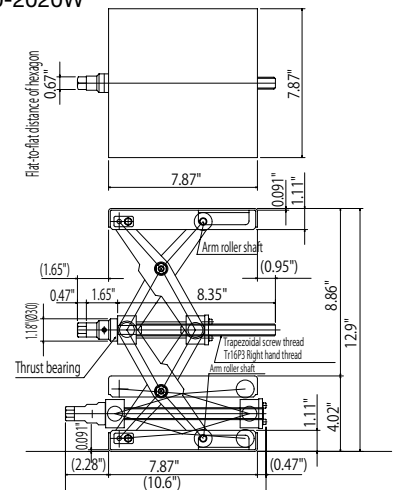

**Load capacity:** 220 to 661 lbs

Unit: inch

Model	Load capacity	Table dimensions (W x L)	Stroke (ST)	Table height (H to H1)	Lift method	Number of rotation	Deadweight
MH-100-2020W	331 lbs (Static)* 220 lbs (Dynamic)*	7.9" x 7.9"	8.9"	4.0" to 12.9"	Trapezoidal screw/ manual	Approx. 30 times	18 lbs
MH-300-4040	661 lbs	15.8" x 15.8"	7.9"	6.3" to 14.2"		Approx. 40 times	66 lbs
MH-300-5050	661 lbs	19.7" x 19.7"	7.9"	6.4" to 14.3"		Approx. 40 times	71 lbs

\* The load capacity of MH-100-2020W is 220 lbs while it is lifting or lowering and 331 lbs while it is stopping.