

# MLSB Mechanical-Electric Lift (Ball Screw, Electric) Ultra-low & Slim

It is possible to directly place a hand-pushed cart or a flat cart currently in use on top of the lift. Work can be more efficient since there is no need to pile up items over again on the table lift.

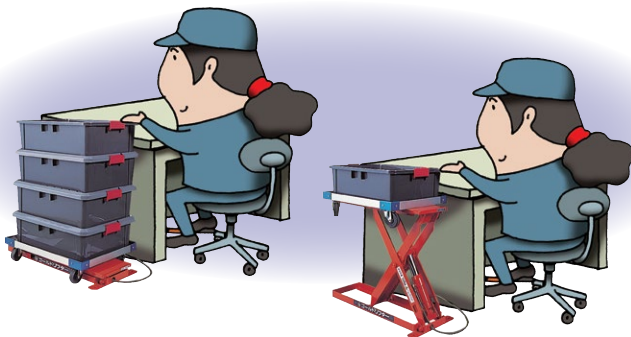

MLSB-100-2007



### MAJOR FEATURES OF THE MLSB SERIES

- Ultra-low platform
- Stand-alone unit
- 115V single-phase power supply
- Foot switch cord: 78.7 in.
- Power cord: 118.1 in.
- Maximum usage frequency: 30 times per hour
- Dry ball screw cylinder

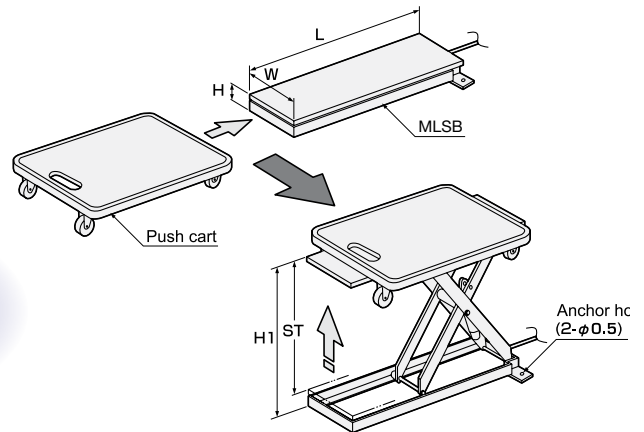

**Load capacity:** 220 / 440 lbs

Unit: inch

	Model	Load capacity	Table dimensions (W × L)	Stroke (ST)	Table height (H to H1)	Lifting duration in seconds	Lowering duration in seconds	Motor Output Watts	Deadweight
Electric ball screw type	MLSB-100-2007	220 lbs	7.9"×27.6"	19.6"	3.2" to 22.8"	12	12	70	62 lbs
	MLSB-100-2507		9.8"×27.6"						66 lbs
	MLSB-100-3007		11.8"×27.6"						71 lbs
	MLSB-100-2009		7.9"×35.4"	75 lbs					
	MLSB-100-2509		9.8"×35.4"	79 lbs					
	MLSB-100-3009		11.8"×35.4"	84 lbs					
	MLSB-200-2008	440 lbs	7.9"×31.5"	21.3"	4.3" to 25.6"	12	12		91 lbs
	MLSB-200-2508		9.8"×31.5"						91 lbs
	MLSB-200-3008		11.8"×31.5"						91 lbs

\* When the table is raised from the lowest position to the highest position, the table shifts up to 1.1 in. in the longitudinal direction (direction of L).