

HLH Hydraulic/Manual Foot Pump Bellows

Bellows are attached to the HLH Standard to create a safe work environment.



HLH-100J

During Lowering

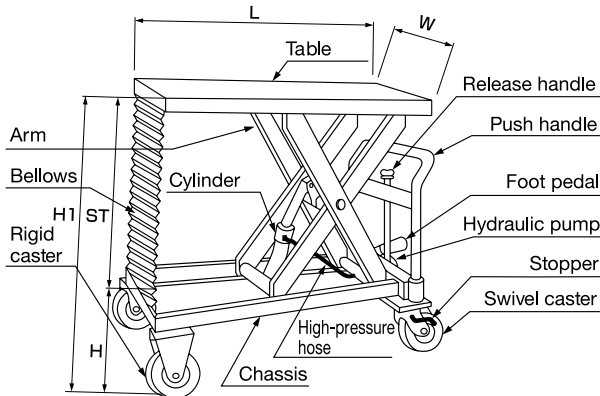

MAJOR FEATURES OF THE HLH SERIES

- Hydraulic cylinder
- Swivel casters with brakes (double stoppers, not available in HLH-150J)
- Foot pedal type
- Comes with an overloading prevention device *1
- Complete bellows skirting
- Rapid pump (The pump mode switches from fast to standard when loaded 20% of capacity.) *2
- Has a springback mechanism in the release handle. In an emergency, lowering will stop as soon as you release the handle

OPTION

- Rapid pump (reduces the number of pump steps)

SPECIFICATIONS

Oil Used

Turbine oil: ISO VG22

Materials

Bellows : Acrylic resin-coated polyester

Pump : Urethane type resin spray painting

Cylinder : Urethane type resin spray painting

*1 The lift will not elevate when overloaded.

*2 Rapid pump is made available to limited models. See specifications.

Load capacity: 330 to 1103 lbs

Unit: inch

	Model	Load capacity	Table dimensions (W x L)	Stroke (ST)	Table height (H to H1)	Overall Length (LL)	Wheels	Number of pump steps fast/standard	Deadweight
Bellows	HLH-150J	330 lbs	20.5"×33.5"	19.1"	9.3" to 28.3"	41.7"	φ3.9 rubber	Approx. - / 22	99.2 lbs
	HLH-250J	551 lbs	23.6"×37.4"	21.3"	10.4" to 31.7"	41.7"	φ3.9 rubber	Approx. - / 36	147.7 lbs
	HLH-500MJ	1103 lbs	23.6"×41.3"	23.6"	13.0" to 36.6"	50.0"	φ5.9 rubber	Approx. 18 / 42	216 lbs