

HLH Hydraulic/Manual Foot Pump

Standard / Aluminum

Easy move and wide stroke. The hydraulic drift is minimized to 2% or less of full strokes when left for 15 minutes with the maximum load weight.

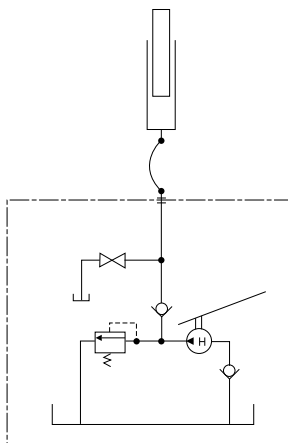

Hydraulic circuit diagram

MAJOR FEATURES OF THE HLH SERIES

- Hydraulic cylinder
- Swivel casters with brakes
- Foot pedal for easy height adjustment
- Overload prevention device *1
- Springback mechanism in the release handle *2

SPECIFICATIONS

Oil Used

Turbine oil: ISO VG22

Materials (Standard)

Pump : Urethane type resin spray painting

Cylinder : Urethane type resin spray painting

Main body : Baked melamine / Powder coating

Materials (Aluminum)

Pump : Aluminum

Cylinder : Aluminum

Main body : Aluminum

*1 The lift will not elevate when overloaded.

*2 In an emergency, lowering will stop as soon as you release the handle.

To raise the lift, tighten the release handle.

This is not attached to the HLH-100 and aluminum models.

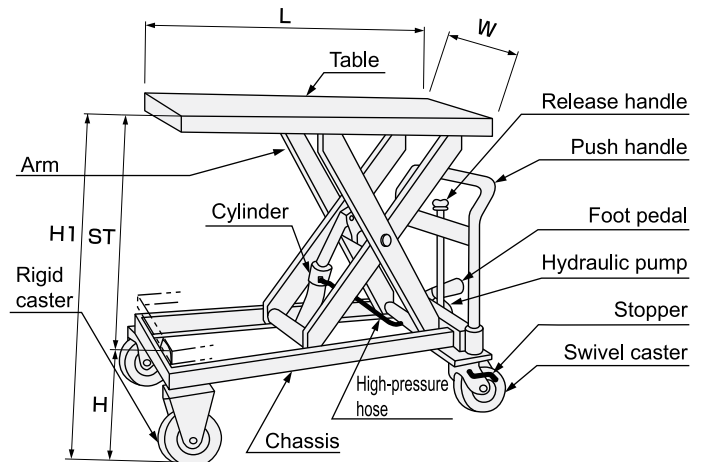

A luminum models are equipped with a handle to make it easier to carry around. It is ideal for lifting/lowering and transporting heavy items on the go.



HLH-A50



Foot pedal and Hydraulic pump



Hydraulic cylinder

Unit: inch

Load capacity: 220 to 2205 lbs

	Model	Load capacity	Table dimensions (W x L)	Stroke (ST)	Table height (H to H1)	Overall Length (LL)	Wheels	Number of pump steps fast/standard	Deadweight
Standard	HLH-100	220 lbs	13.8"×22.4"	15.7"	7.9" to 23.6"	30.1"	φ3.9 rubber	Approx. - / 12	41.9 lbs
	HLH-120	264 lbs	15.7"×28.3"	19"	9.3" to 28.3"	36.6"	φ3.9 rubber	Approx. - / 20	66.1 lbs
	HLH-150W	330 lbs	19.7"×31.5"	43.4"	14.0" to 57.4"	39.8"	φ3.9 rubber	Approx. - / 62	150 lbs
	HLH-200	440 lbs	19.7"×31.5"	21.1"	10.3" to 31.4"	39.8"	φ3.9 rubber	Approx. - / 36	99 lbs
	HLH-300W	661 lbs	23.6"×35.4"	47.9"	16.2" to 64.1"	44.1"	φ5.9 rubber	Approx. - / 85	220 lbs
	HLH-400S	881 lbs	19.7"×31.5"	20.5"	10.9" to 31.4"	39.8"	φ3.9 urethane	Approx. - / 62	136.7 lbs
	HLH-400SW		19.7"×23.6"	27.3"	14.4" to 41.7"	32.1"	φ5.1 rubber	Approx. - / 58	154 lbs
	HLH-400M		23.6"×35.4"	23.6"	13" to 36.6"	44.1"	φ5.9 rubber	Approx. - / 58	176 lbs
	HLH-400L		23.6"×47.2"	34.2"	13" to 47.2"	55.9"	φ5.9 rubber	Approx. 25 / 66	220 lbs
	HLH-500MW	1103 lbs	23.6"×35.4"	49.2"	18.7" to 67.9"	45.7"	φ7.9 urethane	Approx. 49 / 129	374.9 lbs
	HLH-700	1543 lbs	23.6"×35.4"	23.6"	13" to 36.6"	44.1"	φ5.9 urethane	Approx. - / 85	176 lbs
	HLH-1000M	2205 lbs	23.6"×35.4"	23.6"	15.7" to 39.4"	45.7"	φ7.9 urethane	Approx. 35 / 84	286.7 lbs
	HLH-1000L		23.6"×47.2"	33.1"	15.7" to 48.8"	57.5"		Approx. 49 / 129	363.8 lbs

* The push handle of HLH-100 can be folded.

Load capacity: 110 to 176 lbs

	Model	Load capacity	Table dimensions (W x L)	Stroke (ST)	Table height (H to H1)	Overall Length (LL)	Wheels	Number of pump steps	Deadweight
Aluminum	HLH-A50	110 lbs	13.8"×22.4"	15.7"	7.9" to 23.6"	31.5"	φ3.9 rubber	Approx. 6	25.1 lbs
	HLH-A60	132 lbs	15.7"×28.3"	19.7"	8.7" to 28.3"	37.8"	φ3.9 rubber	Approx. 7	30.1 lbs
	HLH-A80	176 lbs	19.7"×31.5"	21.7"	9.1" to 30.7"	40.6"	φ3.9 rubber	Approx. 14	44.1 lbs

*The push handles of HLH-A50, A60 and A80 can be folded.